

Instruction manual

Force and Torque gauges

CENTOR EASY II



ANDILOG Technologies - BP62001 - 13845 Vitrolles Cedex - France

Email: info@andilog.com Website: www.andilog.com

Ph: +33 442 348 340

Contents

| | |
|--|----|
| 1. Introduction..... | 4 |
| 1.1. Presentation | 4 |
| 1.2. Recommendations before use | 4 |
| 1.2.1. Battery | 4 |
| 1.2.2. Sensor | 4 |
| 1.2.3. Test stand | 5 |
| 1.2.4. Test precautions | 5 |
| 1.2.5. Ambient conditions | 5 |
| 1.2.6. Warranty..... | 5 |
| 2. Getting started | 7 |
| 2.1. Battery charging | 7 |
| 2.2. Accessories assembly | 7 |
| 2.2.1. Internal sensor force gauge..... | 7 |
| 2.2.2. External sensor force gauge type S2 or S9 | 7 |
| 2.2.3. TH torque gauge | 9 |
| 2.2.4. TW torque gauge | 9 |
| 2.3. Test stand mounting..... | 10 |
| 3. Using the Centor EASY II..... | 11 |
| 3.1. Start-up..... | 11 |
| 3.2. Switching off..... | 12 |
| 3.3. Measurement screen | 13 |
| 3.3.1. Go Zero | 14 |
| 3.3.2. Change unit of measure | 15 |
| 3.3.3. Change display order | 15 |
| 3.3.4. Auto-off..... | 15 |
| 3.3.5. Memory backup..... | 15 |
| 3.4. Menu | 16 |
| 3.4.1. DATA menu..... | 16 |
| 3.4.2. DISPLAY menu..... | 17 |
| 3.4.3. SET POINTS menu | 18 |
| 3.4.4. I/O menu..... | 19 |

| | |
|--|----|
| 3.4.5. SYSTEM menu | 20 |
| 3.5. USB communication | 21 |
| 4. Maintenance and repair | 23 |
| 4.1. Main faults and solutions | 23 |
| 4.2. EC declaration of conformity..... | 24 |
| 4.3. Technical data..... | 25 |

1. Introduction

1.1. Presentation

Thank you for choosing CENTOR EASY II force and torque gauges from ANDILOG.

This instrument is the result of over 35 years of experience in force and torque measurement. It incorporates the latest available technologies to deliver industrial-level performance and measurement quality.

1.2. Recommendations before use

1.2.1. Battery

The Centor EASY II is equipped with a learning battery management component. This component updates itself in real time according to battery wear. For the first few charge/discharge cycles, the percentage of battery remaining may not be very accurate. This accuracy improves after a few cycles and will be updated throughout the battery's life cycle.

Battery life is 15 hours in normal operation. The force gauge should be charged when the battery is empty after normal use. If the force gauge is not used for a long period, it should be kept with a battery charge of between 30 and 80% of its autonomy.

We recommend that you use the original power supply supplied by Andilog to recharge your instrument. The power supply must have the following characteristics: micro-USB, 5V, 1A minimum.

Rechargeable batteries have a limited number of charge cycles and may need to be replaced. Battery life and number of charge cycles vary with use and settings.

1.2.2. Sensor

Never connect accessories or fixtures (hooks, trays, etc.) directly to the load cell. Use the extension cable supplied with your instrument.

Despite this instrument's overload protection, applying a force greater than the load cell's capacity can damage the force gauge or torque gauge. This instrument is equipped with an overload counter which provides information on the operating conditions of the device.

It is important that the measured values are generally below 90% of the sensor's capacity. Constantly operating the load cell above 90% of its capacity can lead to premature wear. When the force gauge is used on a motorized frame, it is necessary to program the frame to stop when the force approaches the maximum capacity of the load cell. This limit must consider that, at high speeds, a frame will not stop immediately, and the risk of damage to the load cell is high due to the motor's inertia.

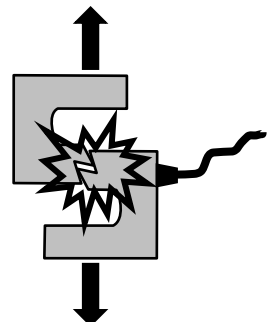

1.2.3. Test stand

The force gauge or torque gauge can be fixed to a frame using M5 or 10-32 screws. **The length of the screws used must not exceed 3mm inside the instrument.** Contact Andilog if you need further information or if you require an adapter to mount the instrument on a frame.

1.2.4. Test precautions

Most of the tests carried out with instruments from the Andilog Technologies range are destructive tests. The hazards associated with this type of testing require our instruments to be used by experienced and trained operators. Due to the nature and use of the equipment sold by Andilog, the purchaser's acceptance of Andilog Technologies' products constitutes acceptance of the risks and damages that may result from the use of Andilog's instruments.

1.2.5. Ambient conditions

- Operating temperature: 0 to 35° C
- Storage temperature: -20 to 45° C
- Relative humidity: 5% to 95%, non-condensing
- Maximum operating altitude: 3,000 m

1.2.6. Warranty

Subject to the conditions below, Andilog Technologies warrants to the purchaser that it will repair or replace at no charge new instruments sold subject to normal use and maintenance. This warranty applies if the purchaser detects a defect in workmanship or materials within a period of two (2) years from the date of shipment.

The conditions of application are:

- ANDILOG was notified in writing of the defect before the end of the warranty period.
- Products are shipped to Andilog Technologies with prior agreement from Andilog Technologies.
- All transport costs are paid by the buyer.
- The products have been used and maintained under normal conditions of use.

Any repair or replacement carried out by the seller without the agreement of Andilog Technologies voids the warranty.

In no event will Andilog be liable for any damages, business interruption or production stoppage arising from the purchase, use or non-operation of our products. Even if Andilog has been informed of the possibility of such damage.

The accuracy of our devices is guaranteed at the time of shipment at the value indicated in our documentation or offers.

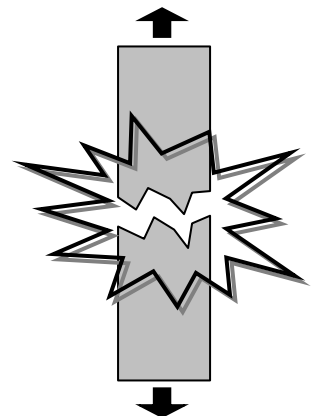

If products are damaged during shipment, notify the carrier and Andilog Technologies immediately.

The warranty is void in the event of accident, misuse, or abuse.

The warranty does not cover calibration, overloaded sensors, or consumable parts such as batteries, unless the damage is due to a material or manufacturing defect.

2. Getting started

The usual functions (display force or torque, display maximum, zero and change units) can be accessed simply by using the keys on the keypad.

2.1. Battery charging

Connect the AC adapter to the micro-USB connector on the left-hand side of your instrument. The green LED on the front panel lights up when the battery is charging. When charging is complete, the LED goes out.

2.2. Accessories assembly

2.2.1. Internal sensor force gauge

Attach the extension cable supplied in the case to the load cell stem at the bottom of the force gauge. Tightening should be done by hand, without applying excessive torque. Excessive torque or the use of pliers can damage the load cell. We recommend that you fit the accessories with the force gauge switched on, to ensure that you do not apply a heavy load to the load cell when fitting the accessories.

2.2.2. External sensor force gauge type S2 or S9

Mounting precautions for S2 and S9 external load cell force gauges are :

- S2 and S9 force load cells are fitted with strain gauges. These are protected by white silicone. Your accessories, screws, etc. must not come into contact with this silicone. This would prevent measurement and risk destroying the sensor.
- Torsion, bending and shear loads are disruptive factors and should be avoided.

S2 sensor :

Maximum tightening torque for mounting and accessories: 15Nm.

Mounting direction:

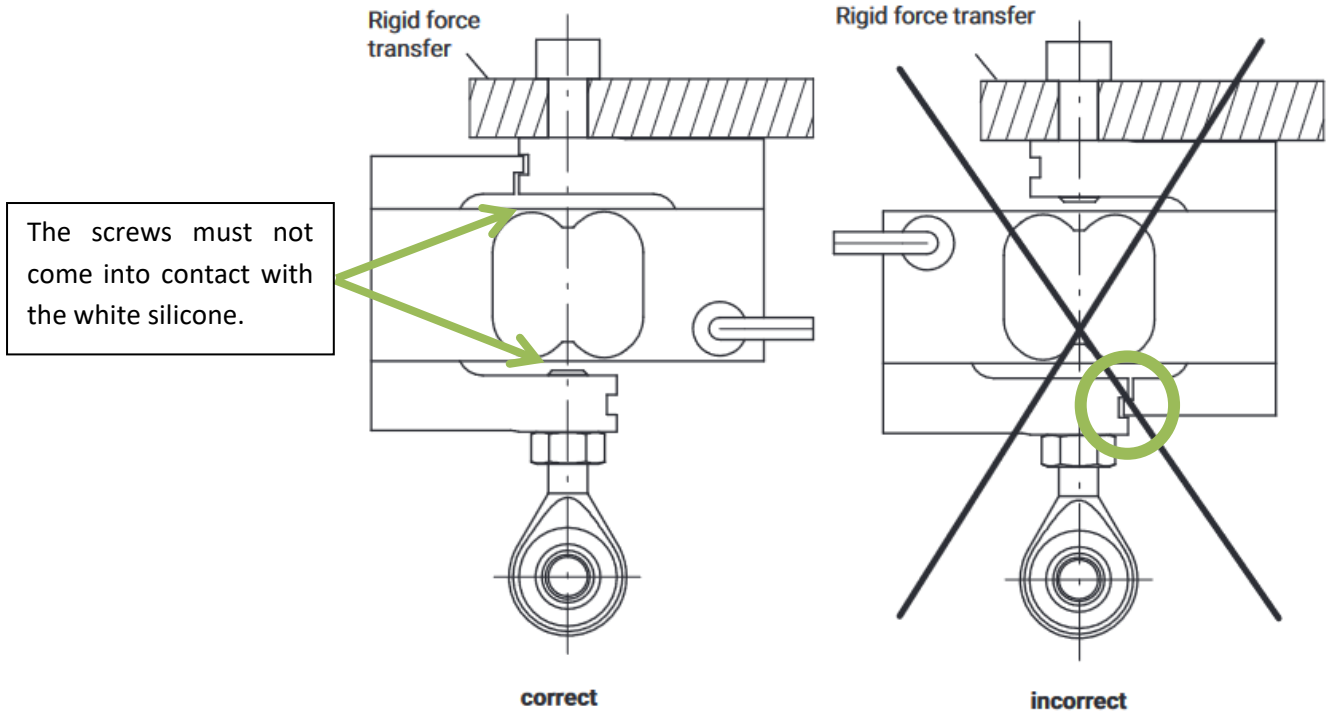

S9 sensor:

Maximum tightening torque for mounting and accessories:

- For load cells up to 10kN: 50Nm (M12)
- For 20kN load cells: 200Nm (M24x2)
- For 50kN load cells: 500Nm (M24x2)

Mounting direction:

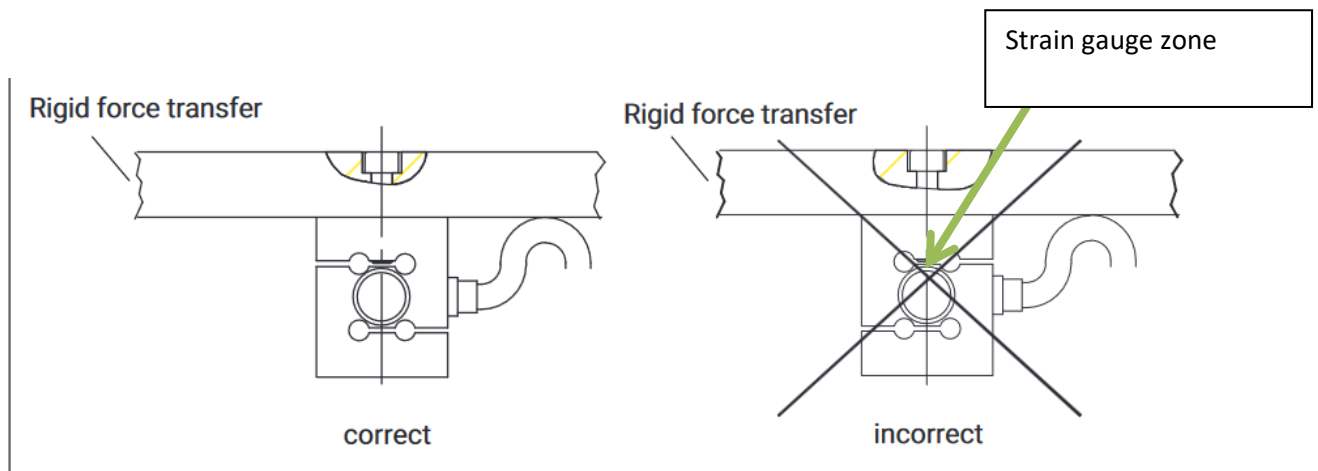

2.2.3. TH torque gauge

TH torque gauges are equipped with a dismantling chuck. The square used on the TH chuck is a 3/8" square. It is retained on the side by a support screw.

Screw features:

- 6 hexagon socket UNC 6-32 thread, 5/16" long
- 6-pan wrench size: 1/16".

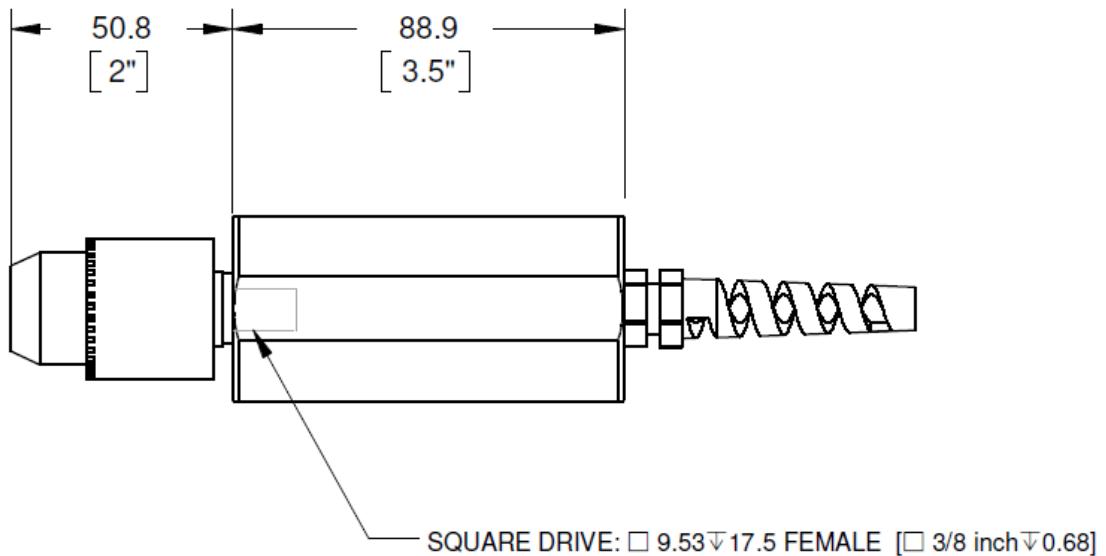

2.2.4. TW torque gauge

TW torque gauges are fitted with a male square. The dimensions are as follows:

- 15 and 60Nm: 3/8"
- 150Nm: 1/2"

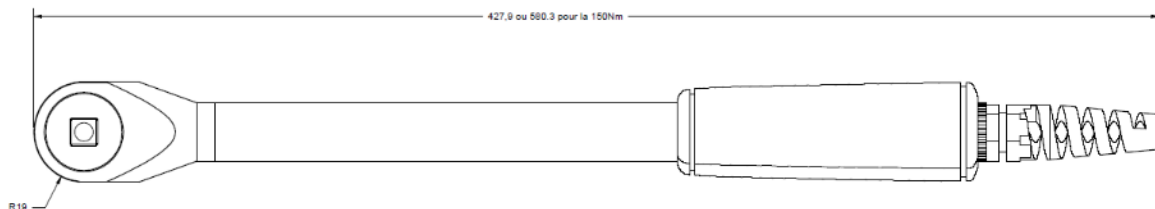

Measurements with the TW sensor must be taken along the axis of the square. Using an extension on the square to change the axis of measurement will result in a false measurement.

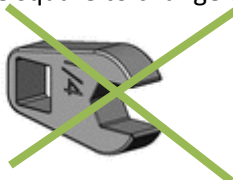

2.3. Test stand mounting

On the back of the force gauge are 2xM5 and 2x10-32 threaded holes which can be used to mount the force gauge on an ANDILOG frame. Each ANDILOG frame is supplied with a special spacer and fixing screws for this purpose.

If you wish to use another type of frame, check that the screws used have a maximum length of 3mm. Although threaded holes are blind, the use of longer screws may destroy components on the electronic board inside the instrument.



3. Using the Centor EASY II

3.1. Start-up

Please note that the Centor EASY II measures very small variations in force or torque and may not display exactly zero if moved during its self-test procedure. When correctly mounted and zeroed, the reading remains stable.

Start-up is performed by pressing the  key, a short self-test procedure displays the following screen:



After the self-test, if the unit is functional, the force gauge displays the measurement screen. It then displays 0 N. A tare is performed when the unit starts up.

If the force applied is greater than:

- 10% of maximum capacity, a warning message is displayed at start-up indicating the percentage of force applied to the load cell. The force gauge can still be used, but we recommend using accessories weighing less than 10% of the load cell's capacity.
- At 20% of maximum capacity, the force gauge displays a maintenance screen. At the bottom of this screen, the force applied in % is indicated. The unit cannot be used if the start-up force is greater than 20%. In this case, switch off the force gauge and remove the preload before switching it on again.

For example, for a force gauge with a capacity of 500N, the force applied to the load cell must not exceed 100N at start-up.

Force applied at force gauge start-up (must be less than 20%)

Value of the maximum force applied to the load cell

Counter for the number of overloads applied to the load cell

Displayed in orange if the next calibration date has passed

Battery voltage

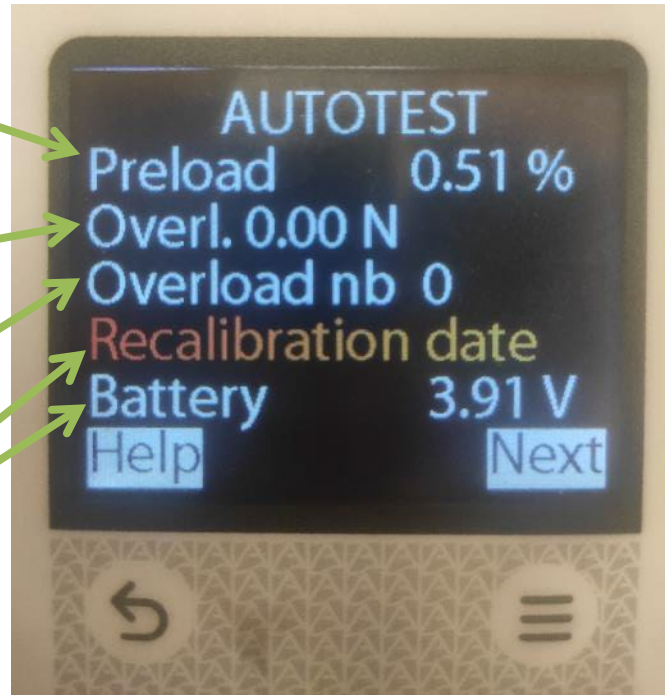

All settings are stored in memory when the force gauge is switched off. The force gauge will operate with the same settings when switched back on (unit, display order).

3.2. Switching off

To switch off the Centor EASY II, press and hold the  button until the instrument switches off (5 seconds).

3.3. Measurement screen



Battery indicator: varies between 0% and 100% to show battery life. When the battery is new, it will last approximately 15h in continuous use. When the battery percentage reaches 0%, the force gauge switches off.

Capacity display: indicates the capacity of the sensor installed in the instrument, as well as the unit of measurement.

Bar graph: The bar graph shows the operator how much force is being applied relative to the load cell's maximum capacity. When a compressive force is applied, the bar graph fills upwards. When a tensile force is applied, the bar graph fills in downwards.

Measurement display:

A force applied in traction will be preceded by the symbol ▼

A force applied in compression is preceded by the symbol ▲

Clockwise torque is preceded by the symbol ↻

A counterclockwise torque will be preceded by the symbol ↺

Example for force measurement:

Indicates direction of measurement (tension or compression). Force measured instantaneously

Maximum pull from tare

Maximum compression from tare



Example for force measurement:

Indicates direction of measurement (clockwise or counterclockwise). Torque measured instantaneously

Maximum clockwise

Maximum counter-clockwise



The display order can be changed by pressing the

3.3.1. Go Zero

During tests, it is often necessary to reset the display to zero (e.g. to tare an accessory). Press the **green 0** key. The display shows 0.

3.3.2. Change unit of measure

You can choose from the following units:

- Force gauge: N, KN, kg, lb, oz, g and daN.
- Torque meter: Nm, mNm, kg.cm, lbin, lbft, ozin.

Some units may not be available, depending on the load cell capacity. For example, for a 150Nm capacity load cell, it is not possible to measure in mNm.

To change the unit display, press the **U** key. Each successive press will select the next unit until you return to the starting unit. The Centor EASY II will automatically convert the display and capacity to the new chosen unit and display the corresponding unit symbol.

The number of decimal places displayed changes according to the unit selected. It corresponds to 1/10,000 of the sensor capacity.

3.3.3. Change display order

The torque meter detects and stores the maximum tension and compression values. Press the  key. The display order of the various values will shift upwards. The top line will then move to the bottom. Each time you press this key, the display changes. Centor EASY II remembers the display order when it is switched off.

3.3.4. Auto-off

Automatic shutdown saves battery charge. The force gauge is automatically switched off after 15 minutes without pressing any key.

3.3.5. Memory backup

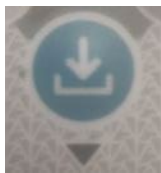

A long press on this key activates or deactivates the maximum memory save function. When this function is activated, the save counter is displayed at the bottom right of the screen. Up to 500 values can be saved.

A short press on this key saves the maximum value in memory, which has a blue arrow in front of it. Each press increments the save counter at the bottom of the screen. Access to the values and setting of the saved value is via the menu.

3.4. Menu

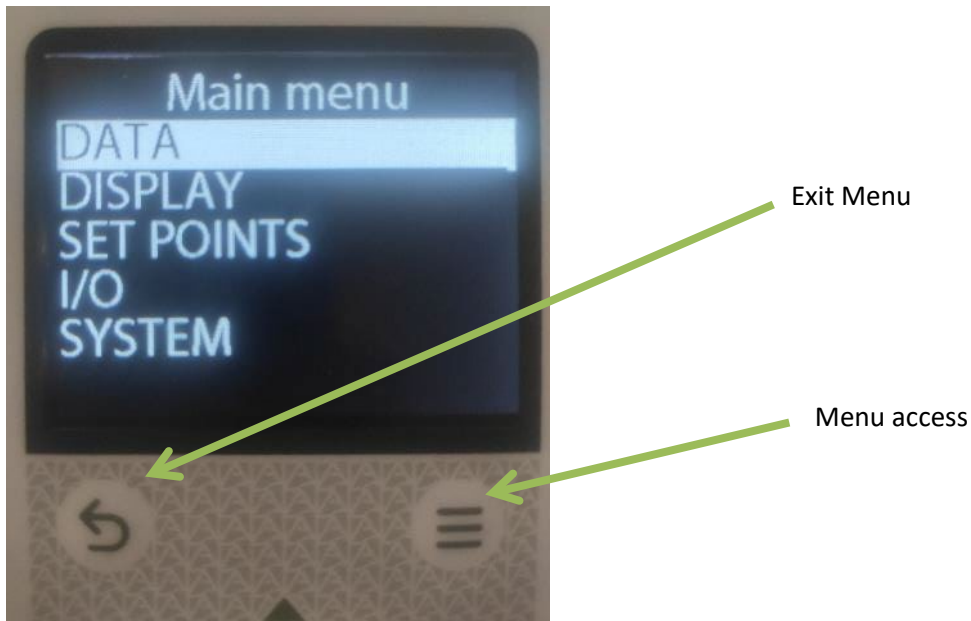

The different menus:

- DATA: Access to stored maximum values
- DISPLAY: Setting the display and automatic switch-off
- SET POINTS: limit setting
- I/O: Setting the I/O
- SYSTEM: access to force gauge information

The keyboard is used to navigate the menu:

- Up and down arrows: change lines
- Right arrow: to enter a menu

3.4.1. DATA menu



The Centor Easy II can store the maximum measured value in memory. It can store up to 500 values. Each value is stored in the following format:

Measurement # Value Date Time

The saved value is indicated by the blue arrow at the top of the screen:

- Upwards, maximum traction
- Downward, maximum compression
- To the right, clockwise
- To the left, anticlockwise

To change the type of value to be saved, move to the "Peak" line, then press the right arrow. A message appears, asking if you wish to delete all values in memory. **Warning: changing the type of value to be saved systematically deletes all values in memory.**

If you wish to clear the memory without changing direction, press and hold the left arrow.

Si vous souhaitez effacer la mémoire sans changer de sens, faites un appui long sur la flèche de gauche.

3.4.2. DISPLAY menu



You can customize the Centor Easy II display to show only the information you need.

The information you can customize is as follows: units displayed, value displayed on each line, Bargraph display, time to auto power off, invert display.

Unit: changes the unit used for measurements. This setting can also be changed directly by pressing the U key on the keypad while in the measurement screen.

Line 1, 2, 3: You can choose what is displayed on each line of the measurement screen. The possibilities are current value, max in each measurement direction and No if you don't want to display this line. Line 1 cannot be disabled.

Bargraph: whether or not to display the Bargraph.

Autooff: time during which the Centor Easy II remains switched on without pressing a key. Adjustable from 1 to 15 minutes. Can be disabled with No.

Reverse: rotates the display by 180°.

3.4.3. SET POINTS menu

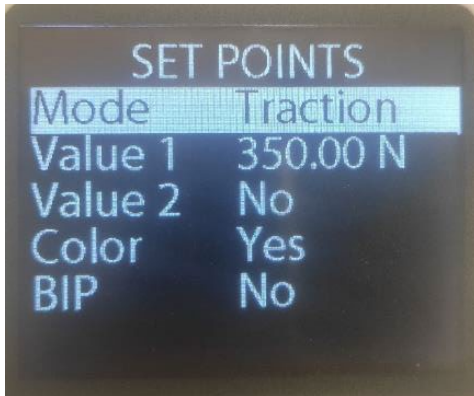

This menu allows you to set thresholds on the force gauge. A sound can be emitted when thresholds are exceeded, and the color of the measurement display can be changed according to thresholds.

Mode: selects whether the threshold is in tension or compression, clockwise (CW) or counterclockwise (CCW).

Value 1 and Value 2: threshold values in the unit of measurement.

Color, BIP: changes the color of measurements if the threshold is exceeded and/or emits a sound.

How it works:

- If Value 1 and Value 2 are 0, the threshold function is deactivated.
- If Value 1 has a value and Value 2 is 0. Only one threshold is activated. In this case, if the maximum of the chosen direction exceeds the value in Value 1, the force gauge beeps and/or the digits turn orange.
- If Value 1 and Value 2 have a value, then there are 2 thresholds set. In this case, if the maximum force exceeds Value 1, the Centor Easy II emits a beep and/or the values turn green. If the maximum force exceeds Value 2, the values change to orange.

Example of use:

1. I've got a 500N force gauge, and I want to shoot a sample. If it breaks above 100N, my parts are good (displayed in green). The settings to be applied are as follows:

Mode: Traction
Value 1: 100N
Value 2: 500N
Color: Yes
Beep: No

2. I have a 100N force gauge and I want to compress a sample. If the force exceeds 50N, my parts are bad (orange display and beep). The settings to be applied are as follows:

Mode: Comp.
Value 1: 50N
Value 2: 0.00N
Color: Yes
Beep: Yes

Bip : Yes

3.4.4. I/O menu

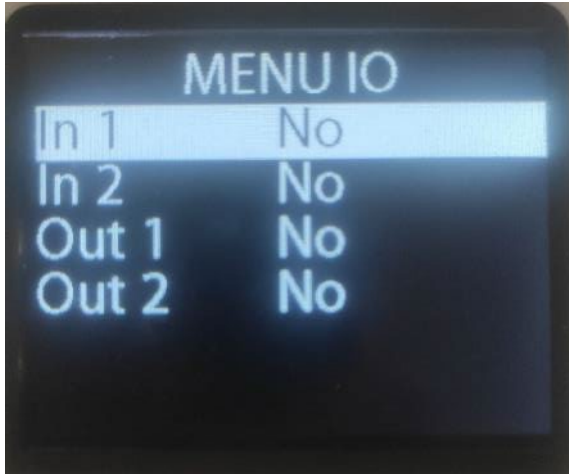

capacity is exceeded

The Centor Easy II has 2 TTL inputs and 2 TTL outputs. These I/Os enable the instrument to be connected to a PLC or other electronic board, for example.

- IN 1 and 2 :
 - - Tare: tare the instrument
 - - Save: saves the value configured in the Data menu in memory
- OUT 1 and 2:
 - - Set point: activated when Value 1 or 2 in the Set points menu is exceeded
 - - Overload: activated when maximum device



Electrical connection: the I/O connector is located on the side of the Centor. There are 8 pins available:

- 1. IN 1
- 2. Ground
- 3. IN 2
- 4. Ground
- 5. OUT 1
- 6. Ground
- 7. OUT 2
- 8. Ground

All grounds are connected together.

IN 1 and IN 2 operation: Centor Easy II detects the activation of an IN1 or IN2 input when the input in

question is connected to ground.

OUT 1 and OUT 2 operation: When the outputs are deactivated, they are in a floating state. When activated, they are grounded. Ideally, they should be used with a pull-up resistor on pins 5 or 7. These outputs are driven by MOSFETs, maximum voltage 42V, nominal current 3A, resistor 50mohms.

Typical schematic :

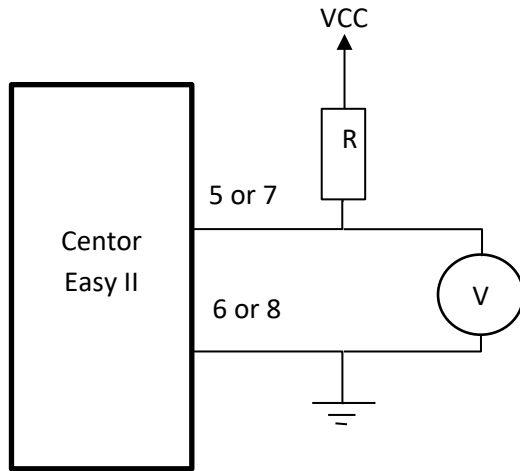

R: pull-up resistor

VCC: Power supply

V: Voltmeter or digital input

Operating example:

R = 10kOhm

VCC = 5V

The input/output connector is of the spring-cage type, and accepts the following connections:

- Wire cross-section 0.14 to 0.5mm² / AWG 24 to 20
- The wire can be removed by inserting a 2.5mm-wide flathead screwdriver into the rectangular part.

3.4.5. SYSTEM menu

Includes all force gauge configuration information:

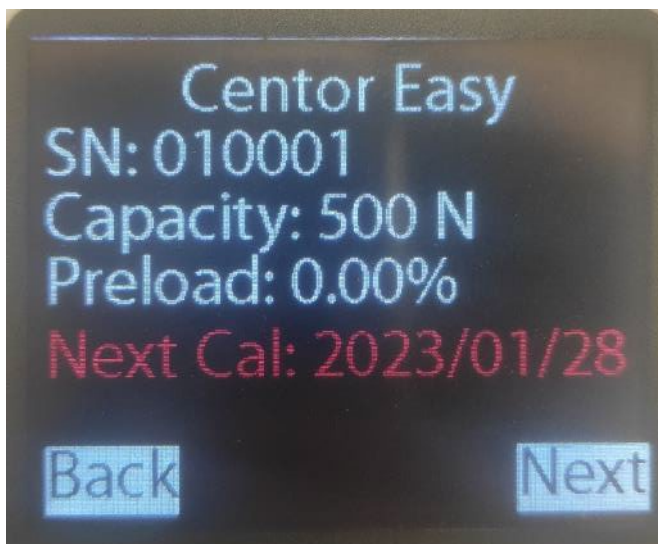

First screen:

- Serial number
- Force gauge capacity
- Load at force gauge start-up in % of capacity
- Next calibration date

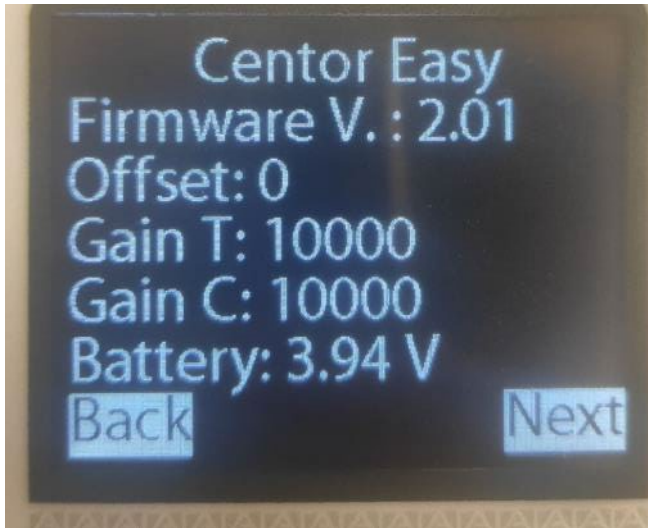

Second screen:

- Internal software version
- Sensor factory offset setting
- Traction gains
- Compression gain
- Battery voltage

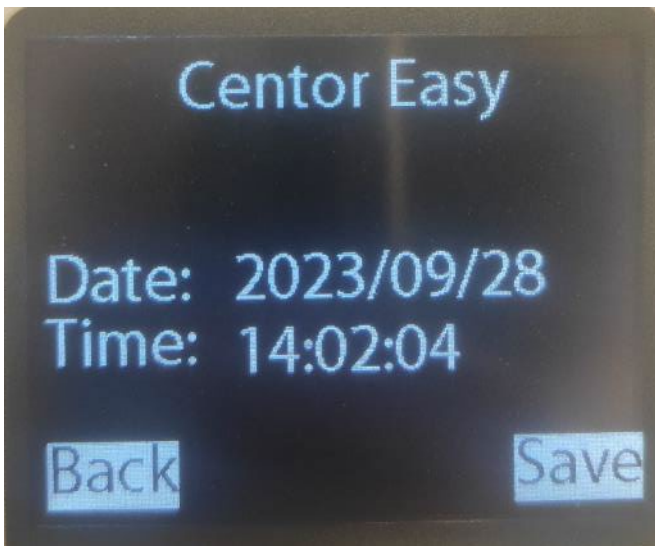

Third screen:

- Today's date
- Time

These values can be modified using the keyboard arrows. Press the right arrow to start editing.

3.5. USB communication

The Centor Easy II is equipped with a USB connection for communication with a computer. It can be connected to our Caligraph software to send continuous data. It can also be connected to a HyperTerminal, LabVIEW or any other data acquisition system. It is then seen as a COM port.

The Centor Easy II adapts its communication parameters automatically and is able to respond automatically to communication speeds of up to 921600 baud. Characters are sent and received in ASCII.

Available controls :

- Start transmission of instantaneous measurements.

- Ordering: 1
- Answer in the form: "Unit value Unit value...".
- Stop transmission of instantaneous measurements.
 - Ordering: 2
- Request to send file of saved maximums (DATA menu contents)
 - Order: T
 - Answer in the form:

"XXX Y/Z Val Unit Date Time \n

....

XXX Y/Z Val Unit Date Time \n "

Where:

XXX represents the measurement number

Y/Z represents the mouse counter (Y: animal counter / Z: trial number)

- Request to send back-up file of saved maximums.
 - Order: R
 - Answer in the form:

"XXX Y/Z Val Unit Date Time \n

....

XXX Y/Z Val Unit Date Time \n "

Where:

XXX represents the measurement number

Y/Z represents the mouse counter (Y: animal counter / Z: trial number)

- Device identification
 - Ordering: ?
 - Device model query.
 - Answer: E
- Tare
 - Order: Z

Receipt of a command, other than a tare or measurement start request, stops the transmission of instantaneous measurements.

Instantaneous measurements are sent when the device is not on the main measurement page. It restarts when you return to the main page (unless a command to the contrary is received).

All data sent is signed. Tensile forces are considered positive, compressive forces negative.

4. Maintenance and repair

4.1. Main faults and solutions

| Problem | Solution |
|--|---|
| My device switches itself off. | <ol style="list-style-type: none"> 1. Check that the battery percentage is not at 0%. Charge the device. 2. The Centor EASY II switches off automatically after 15 minutes if no key is pressed. |
| My device is blocked, the force no longer varies. | Switch off and restart your instrument using the on/off button. |
| My device doesn't display the measurement screen but an information page with Offset in red. | <p>If the offset value is greater than 20%, the device cannot measure. Switch off your device and remove the load applied to the sensor. Then switch on your device.</p> <p>If no load is applied to the sensor, then the sensor is deformed. In this case, return the device to us for replacement.</p> |
| My device does not display the measurement screen but an information page with Overload greater than 10 | You can reset the overload counter to 0 from the Admin menu. To access it, press and hold the "U" key while in the Main menu or Autotest. The Admin menu appears. Go to the Overload line and press the right arrow. Confirm that you wish to reset overloads to 0. Your device is now ready for operation again. |
| My device does not display the measurement screen but an information page with Recalibration date in orange | You can continue measuring. If you want to change the date of the next calibration, go to the Admin menu. To access it, press and hold the "U" key while in the Main menu or Autotest. The Admin menu appears. Move to the Next Cal line and press the right arrow. Use the up and down arrows to change the date. Your device is now ready to use again. |

4.2. EC declaration of conformity

The company Andilog Technologies certifies that the following products:



- Dynamomètres Centor First II
- Dynamomètres Centor First R II
- Dynamomètres Centor Easy II
- Dynamomètres Centor Easy R II
- Couplemètres Centor Easy II
- Couplemètres Anditork First II
- Couplemètres Anditork Easy II
- Ergokit First II
- Ergokit Easy II

Manufactured by:

Andilog Technologies SAS
Immeuble les Bouleaux
ZA de Couperigne
13127 Vitrolles
France

Conform to:

- Requirements of the Electromagnetic Compatibility Directive 2014/30/EU when tested against standard EN 61326-1:2013.

As derivative products of:

Centor Easy II

Tested by:

LGAI Technological Center, S.A. (APPLUS)
Campus de la UAB. Ronda de la Font del Carme, s/n. 08193 Bellaterra (Barcelona) (Spain)

Signature of Authorized Person

A handwritten signature in black ink, appearing to read 'M. LEGRAND', written over a light blue horizontal line.

Printed name

Matthieu LEGRAND

Date

06/03/2024

Title

Operating manager

4.3. Technical data

| Features | Capacity |
|----------------------------------|---|
| Precision | 0.1% of full scale for force load cells (internal, S2, S9) 0.25% of full scale for torque load cells |
| Autonomy | 15h |
| Power supply | MicroUSB, 5V, 1A |
| Net weight | 520 g (internal sensor) |
| Sensor sampling frequency | 2,000 Hz |
| Battery type | Lipo (1 cell, 2000mA) |

Case plan :

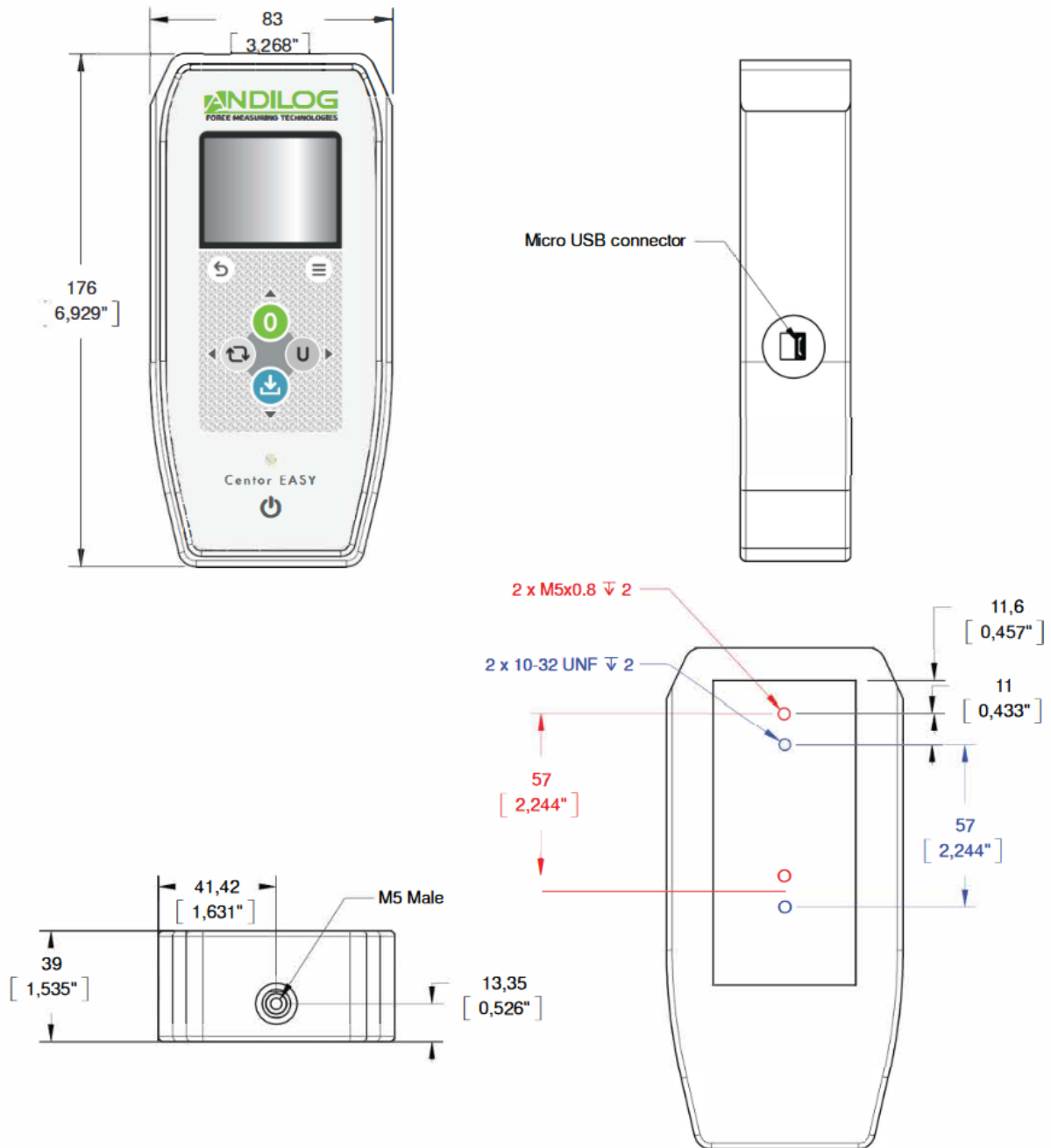

S2 sensor :

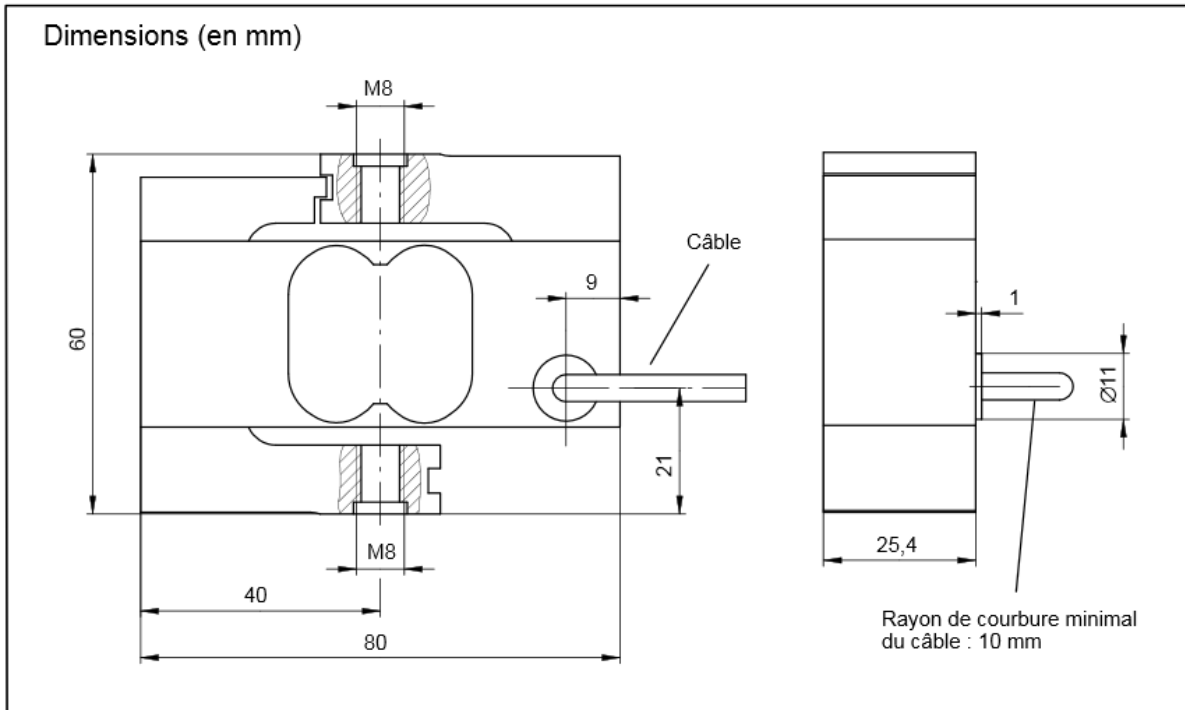

S9 sensor:

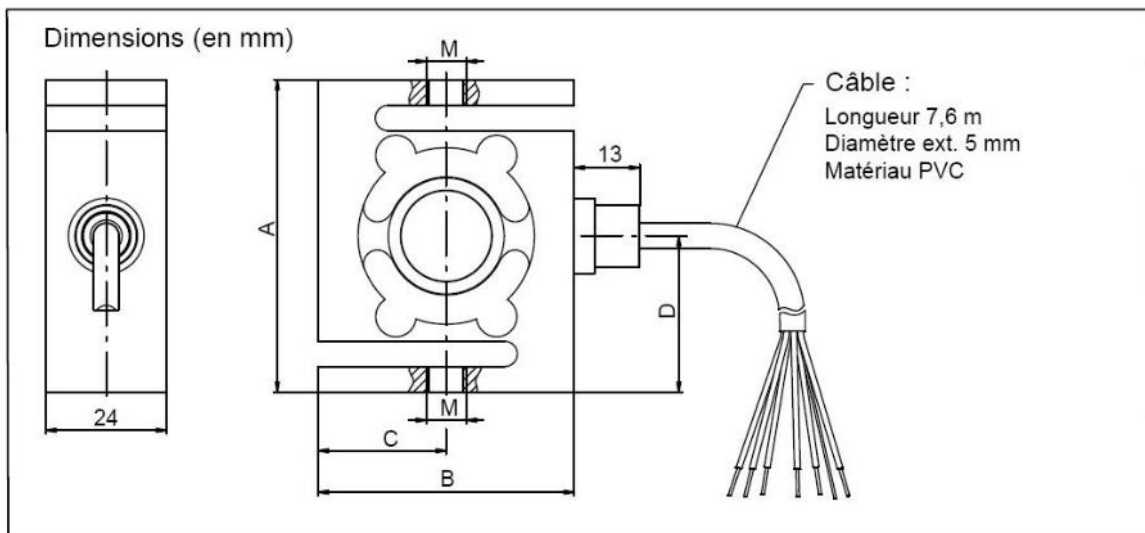

| Type | A | B | C | D | M |
|----------|------|------|------|------|-----|
| S9M/2 kN | 87,3 | 57,2 | 28,6 | 43,7 | M12 |

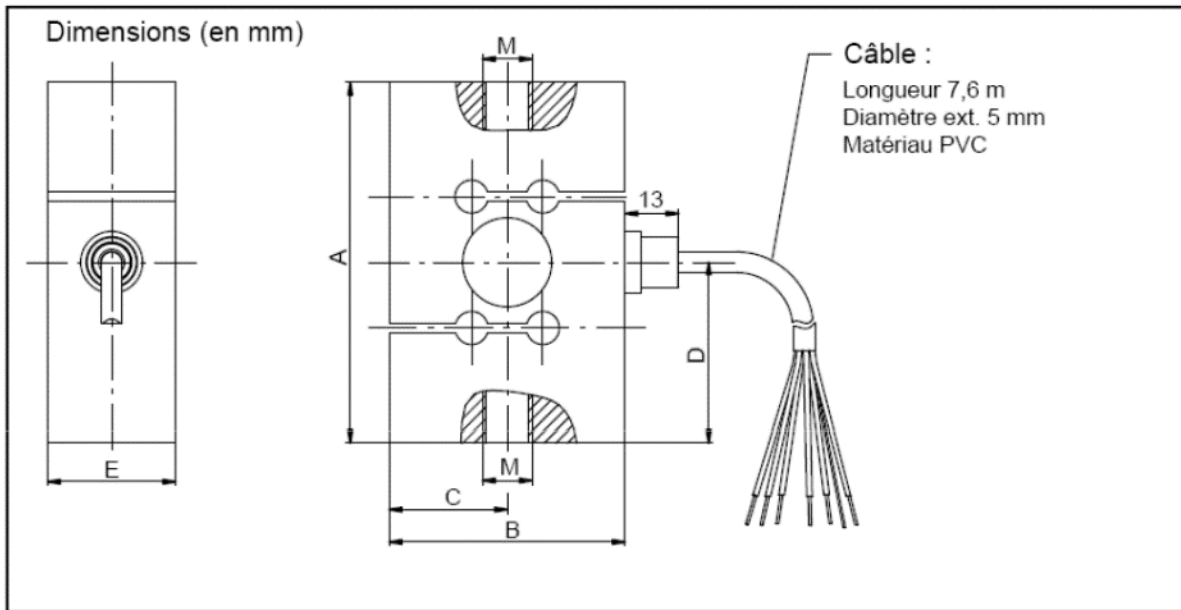

| Type | A | B | C | D | E | M |
|-----------|------|------|------|------|------|-------|
| S9M/5 kN | 87,3 | 57,2 | 28,6 | 43,7 | 31 | M12 |
| S9M/10 kN | 87,3 | 57,2 | 28,6 | 43,7 | 31 | M12 |
| S9M/20 kN | 100 | 69,8 | 34,9 | 50 | 31 | M24x2 |
| S9M/50 kN | 100 | 76,2 | 38,1 | 50 | 36,5 | M24x2 |

TH sensor :

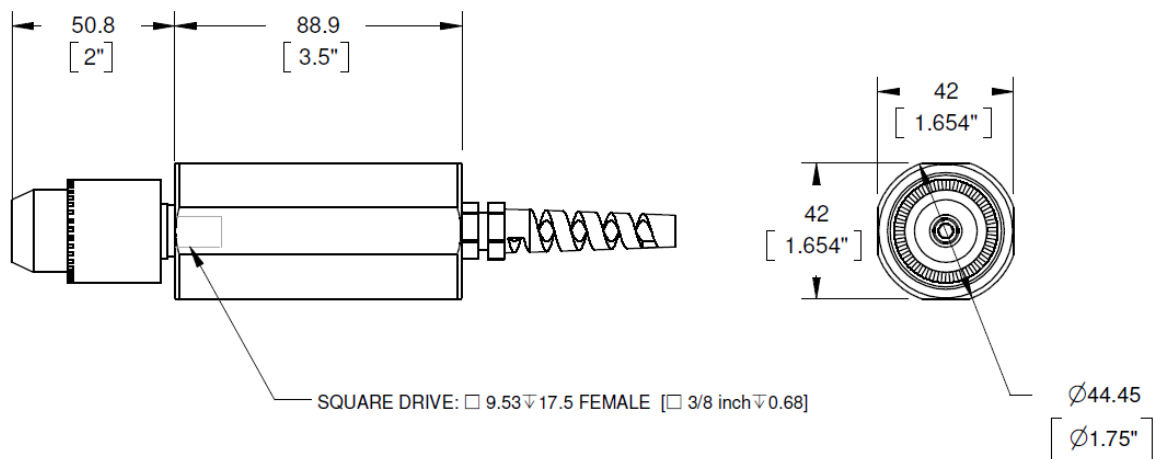

TW sensor :

